

Double Box with TwinCONTACT

Part no. 1649



- screwless spring terminals
- CEE and receptacle SCHUKO® in one enclosure
- also available with shock-proof receptacles to comply with French/Belgian, Danish and Swiss standards

Technical specifications

CEE 16 A, 5 p, 400 V	1
SCHUKO® 16 A, 230 V	1
Protection type	IP 44
Enclosure material	Plastic
Weight	375 g
Declaration of Conformity	RU,EAC (Zwangszulassung), NL,Kema

Drawing

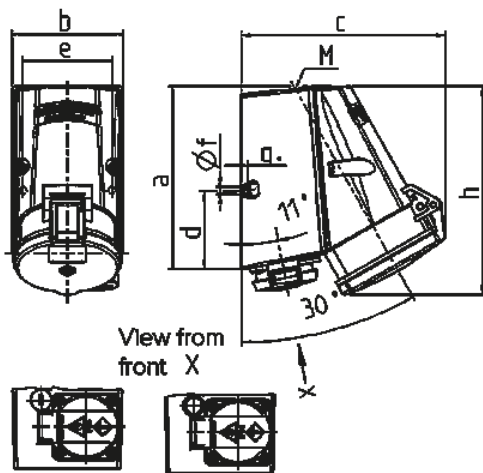

Drawing 1 MB 354	Amp. Poles	16		32
		4	5	5
Dim. in mm	a	141	141	141
	b	84	84	85
	c	136	140	158
	d	61	61	61
	e	68	68	68
	f	5.5	5.5	5.5
	g	5	5	5
	h	142	145	161
	M	25	25	25
Max. cable diam. (mm)		18	18	18
Terminal for cond. cross section (mm ²) min.-max.		1.5	1.5	2.5
		—4	—4	—10